

CHARGING MULTIPLE BATTERIES

Using 12 volt batteries.

PARALLEL CONNECTION

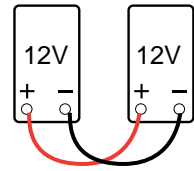

SERIES/PARALLEL CONNECTION

Using 6 volt batteries.

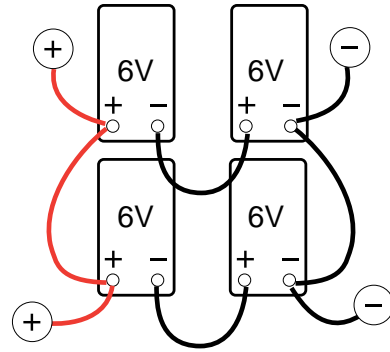

Multiple batteries (engine starting, deep cycle, sealed, gelled, agm, maintenance-free) can be charged at the same time in parallel (+ to +, - to -). Connect each 12v battery to one another using 18 - 20 gauge (lamp cord type) insulated wire, stripped at the points you wish it to be in electrical contact with the posts of each battery. *VDC Electronics, Inc. does not provide any type of wire harness to accomplish this due to size variations and terminal configuration.* Attach BatteryMINDER to the + and - of any ONE of the 12v batteries.

Simply attaching **BatteryMINDER** to the + and - terminals of either set of series connected 6v batteries. NOTE: If **BatteryMINDER** does not start blinking within 72 hours of the time you attached it to fully charged batteries (1 - 6) YOU MUST DISCONNECT ONE OR MORE OF THE BATTERIES UNTIL BatteryMINDER begins to blink continuously, or press the desulphation button to begin desulphating batteries. Failure to do so will cause the unit to possibly burn out, voiding the warranty.

ONE (1) YEAR 100% UNCONDITIONAL MONEY BACK GUARANTEE:

BatteryMINDER is Guaranteed to perform as claimed or WE will refund your full purchase price, including all taxes, shipping or handling cost applicable to the purchase. Unit must be returned with Proof of Purchase directly to VDC Electronics, Inc., NOT TO THE DEALER FROM WHICH IT WAS PURCHASED.

5 YEAR LIMITED WARRANTY

(This limited warranty is not transferable) VDC Electronics, Inc. warrants this product for FIVE years from date of purchase at retail against defective material or workmanship. It will be repaired or replaced at no charge providing it is returned to VDC Electronics, Inc., freight prepaid together with proof of purchase. We make no warranty other than this limited warranty and expressly exclude any implied warranty including any warranty for consequential damages.

Return unit to:

VDC Electronics, Inc., 83 Cedar Lane, P.O. Box 5537, Englewood, NJ 07631-5537.



VDC ELECTRONICS, INC.

83 Cedar Lane, PO Box 5537, Englewood, NJ 07631-5537
Tech Support 800-379-5579 x206

Operating – Safety Instructions Models: 12041-12v, 24021-24v, 36131 36v

BatteryMINDER®

MAINTENANCE CHARGER-DESULPHATOR

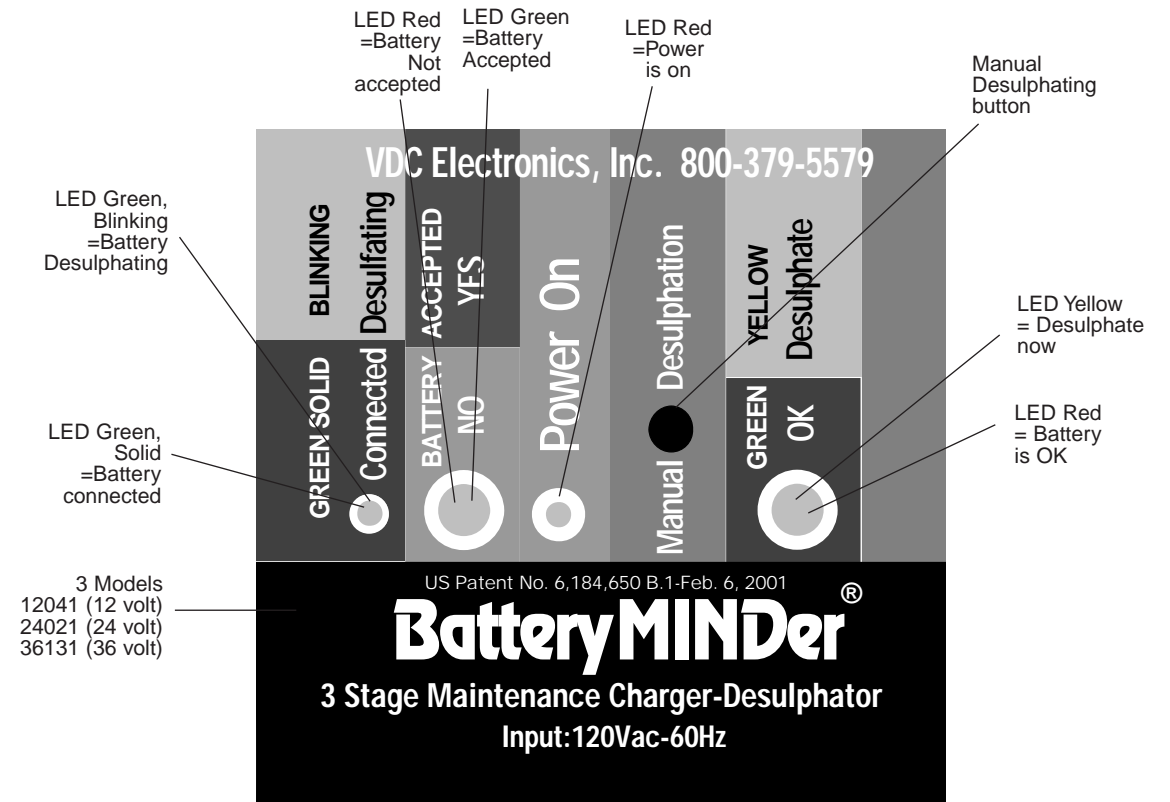

Note: Your BatteryMINDER can be left safely connected (and operating) to any charger, generator, alternator, inverter, without fear of damage.

ALWAYS READ SAFETY INSTRUCTIONS CONTAINED HEREIN BEFORE USING YOUR BatteryMINDER.

QUICK START INSTRUCTIONS:

ALWAYS ATTACH UNIT TO BATTERY BEFORE PLUGGING INTO AC POWER SOURCE. DO NOT PLUG UNIT INTO AC ELECTRICAL OUTLET UNTIL ADVISED LATER HEREIN.

1. Attach Battery to output cord set of unit observing polarity markings RED + (positive), BLACK - (negative)
2. Observe LED "Green Solid" If lit Green proceed, if not lighted check polarity and connections to battery " Green Solid " LED MUST be lit for unit to function.
3. Observe LED Indicator "Battery Accepted" If Green (Yes) = Battery is Accepted for charging- desulphating If RED (No) = Battery cannot be safely charged or desulphated (if just recently deeply discharged (with in 1-5 hours), see inside detailed instructions before discarding battery).
4. Observe LED "Green OK" If lit Green plug unit into AC power outlet. If Yellow = battery requires desulphating

if already fully charged*. Plug unit into 120 volt ac power source. Then press "Manual Desulphation" button to begin process. "Green Connected" LED will now blink continuously, unless battery is bad or unit is disconnected. Observe LED "POWER ON" = Unit functioning and power source is on. (If not lit check AC input power to your outlet).

5. Observe LED "Green Solid" = unit is charging. When charging is completed Green LED will BLINK, (unit is now giving battery a maintenance charge + desulphating, if needed) It will continue blinking indefinitely, until disconnected from battery.

* Read Full Detailed Instructions Before Proceeding Further.

Note:

- Always DESULPHATE - CONDITION ONE (1) BATTERY AT A TIME, unless batteries are in series. If in series-parallel desulphate 1 pair (2) of series connected batteries at one time.
- NEVER attach output cord sets (battery clips or ring terminal-plug assembly) to any other unit except your BatteryMINDER, as polarity may be different on other devices, causing serious potential damage to you and your battery.

HOW TO QUALIFY YOUR BATTERY

You have purchased the number #1 rated "Computer Chip" maintenance charger / desulphator with both Auto-Float Control™ and the newest technological innovation Pulse Mode™ Circuitry. Please carefully follow these special instructions and the standard safety and operating instructions for both maximum safety and complete performance satisfaction.

Note: If your battery does not have a minimum "resting" voltage* it cannot be charged or desulphated.

Minimum Resting Voltage:

12V = 10.5V, 24V = 21V, 36V = 31.5V
(Resting voltage = Voltage in a battery that has not been charged or discharged within 8 hours MINIMUM).

It is extremely important that you determine the state of your battery's "Health" before attempting to re-charge and desulphate your battery. If any of your cells are shorted (no reading on the hydrometer tester) or the difference in charge level is greater than 0.50 SG between any 2 cells (= 2 ball difference using a hydrometer), your battery cannot be properly re-charged / desulphated. Discard the battery in an appropriate, lawful manner. Thank you for purchasing our product and returning the warranty card enclosed.

**Underwriters Laboratories (UL)
REQUIRED SAFETY
INSTRUCTIONS**

1. Do not expose charger to rain or snow. It is designed to operate ONLY INDOORS.
2. USE of any attachment not specifically recommended by the battery charger manufacturer for use with this exact model of charger may result in risk of fire & electric shock or injury to person.
3. An extension cord should not be used, unless absolutely necessary. Use of an improper extension cord could result in fire or electric shock. If extension cord must be used be sure: a. Pins on plug of extension cord are the same number, size, & shape of plug on charger b. Extension cord is properly wired and in good condition.c.Wire size is large enough for AC ampere rating of charge as specified below:
Length of cord, feet (meters)
25(7.6) 60(15.2) 100(30.5) 150(45.6)
AWG Size 18
4. Do not use charger if it received a sharp blow, been dropped, or damaged.
5. Charger contains no serviceable parts. If it fails for any reason, return to the address shown within for a free replacement under warranty.
6. To reduce risk of electric shock, unplug charger from outlet before attempting any maintenance or cleaning.
7. **WARNING - RISK OF EXPLOSIVE GASES. WHENEVER YOU WORK NEAR A LEAD ACID BATTERY IT IS DANGEROUS. BATTERIES GENERATE EXPLOSIVE GASES DURING NORMAL BATTERY OPERATION. FOR THIS REASON, IT IS OF UTMOST IMPORTANCE THAT EACH TIME BEFORE USING YOUR CHARGER, YOU READ THIS MANUAL AND FOLLOW THE INSTRUCTIONS EXACTLY.**

To reduce risk of battery explosion, follow these instructions and those published by the battery manufacturer and the manufacturer of any equipment you plan to use in the vicinity of the battery. Review cautionary markings on the products and the engine.

8. **PERSONAL PRECAUTIONS** when working with/near a lead acid battery.
 - a. Someone should be able to hear your voice or close enough to aid you when working near a lead acid battery.
 - b. Have fresh water and soap nearby case battery acid contact skin, clothing, or eyes. Wear complete eye protection and clothing protection. Avoid touching eyes while working near battery.
 - d. If battery acid does contact skin or clothing, wash immediately with soap and water. If acid entered the eye, immediately flood the eye with running water for at least 10 minutes and get help immediately.

- e. NEVER smoke or allow a spark of flame near battery or engine.
- f. Be extra cautious to reduce risk of dropping a metal tool or auto part onto battery. It might spark or short circuit battery or other electrical part that may cause an explosion.
- g. Remove personal metal items such as rings, bracelets, necklaces, and watches when working with a lead acid battery. A lead acid battery can produce a short circuit current high enough to weld a ring or the like to metal, causing a severe burn.
- h. Charger is designed to be used for recharging lead acid batteries ONLY. Never use it to power a low voltage electrical system, or for attempting to recharge dry cell batteries that are commonly used in house holds. These batteries may explode and cause injury to persons and damage property

NEVER CHARGE A FROZEN BATTERY OR ONE AT A TEMPERATURE ABOVE 123° F.

PREPARING TO CHARGE

- a. If necessary to remove battery from equipment to charge, always remove ground terminal first. Turn off all accessories in the vehicle, so as not to cause an arc.
- b. Be sure area around battery is well ventilated while battery is being charged. Gas vapors can be forcefully blown away by using a piece of non-metallic material as a fan.
- c. Clean battery terminals. Be careful to keep corrosion from contacting eyes.
- d. Add distilled water to each cell until battery acid reaches level specified by the manufacturer. This helps Purge excessive gas from cells. Do not overfill. For a battery with out cell caps, follow manufacturer's recharging instructions.
- e. Study all battery manufacturer's specific instructions such as removing cell caps while charging and recommended charge rates.
- f. Determine voltage of battery by referring to equipment owner's manual and make sure that charger output voltage is correct.

CHARGER LOCATION

- a. Make sure charger is as far away from battery as output cables permit.
- b. Never place charger directly above battery being charged; gases from battery will corrode and damage charger.
- c. Never allow battery acid to drip on charger when reading specific gravity or filling.
- d. Do not operate charger in a closed-in area or restrict ventilation in any way.
- e. Do not set battery on top of charger.

DC CONNECTION PRECAUTIONS

- a. Connect and disconnect DC output clips from battery only after removing charger from outlet.
- b. Attach clips to battery posts and twist or rock back and forth several times to make good contact. This tends to keep clips from slipping off terminals and reduces risk of sparking.

FOLLOW THESE INSTRUCTIONS WHEN BATTERY IS INSTALLED IN EQUIPMENT (VEHICLE, PWC, BOAT, TRACTOR, ETC.) A SPARK NEAR BATTERY MAY CAUSE BATTERY TO EXPLODE. TO REDUCE RISK OF A SPARK NEAR BATTERY:

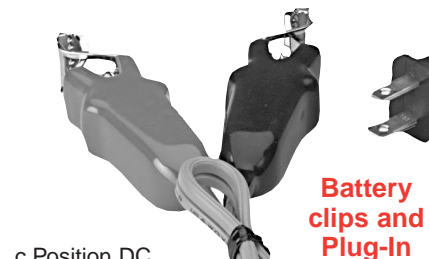

c. Position DC output cord to reduce risk of damage by hood, door, covers, or moving engine parts.

d. Stay clear of fan blades, belts, pulleys, and other parts that can cause injuries.

e. Check polarity of battery posts. POSITIVE (POS, P, +) usually has a larger diameter

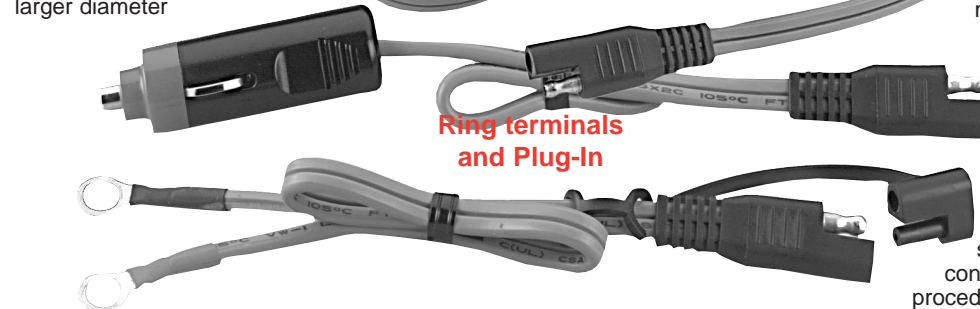

than NEGATIVE (NEG, N, -)POST.

- f. Determine which post of battery is grounded (connected) to the chassis of equipment. If negative post is grounded see Item N. If positive post is grounded see item P. N. For negative grounded equipment, connect POSITIVE (RED) clip from charger to POSITIVE (POS, P, +) ungrounded post of battery. Connect NEGATIVE (BLACK) clip to vehicle chassis or engine block away from battery. Do not connect clip to carburetor, fuel lines, or metal body parts.
- g. For positive ground equipment, connect NEGATIVE (BLACK) clip from charger to NEGATIVE (NEG, N,) UNGROUNDED POST OF BATTERY. Connect POSITIVE (RED) CLIP to chassis or engine block away from battery. Do not connect clip to carburetor, fuel lines, or sheet metal body parts. Connect to heavy gauge metal part of frame or engine.

- h. When disconnecting charger, disconnect charger from AC outlet, then remove clips from vehicle chassis, and battery posts.

Operating instructions for charge information. FOLLOW THESE STEPS WHEN BATTERY IS OUTSIDE OF VEHICLE OR EQUIPMENT.

A SPARK NEAR THE BATTERY MAY CAUSE BATTERY EXPLOSION. TO REDUCE RISK OF A SPARK NEAR BATTERY:



a. Check polarity of battery posts. POSITIVE (POS,P,+) usually has a large diameter than NEGATIVE (NEG, N, -) battery post.

b. Connect (RED) charger clip to (POS+) post of battery.

c. Position yourself and free end of cable as far away from battery as possible, then connect

NEGATIVE (BLACK) charger clip to free end of cable.

d. Do not face battery when making final connections.

e. When disconnecting charger, always do so in reverse sequence of connecting procedure and break

first connection while as far away from battery as practical.

- f. A marine (boat) battery must be removed and charged on shore. To charge it on board requires equipment specifically designed for marine use.

**MAINTENANCE INSTRUCTIONS
DO NOT ATTEMPT TO REPAIR. UNIT IS NOT DESIGNED TO BE REPAIRED. ALL SERVICING SHOULD BE PERFORMED BY VDC Electronics, Inc. PERSONNEL.**

DESULPHATION

Your BatteryMINDer will remove sulphate build-up from the storage plates of your battery automatically or at the push of the button. This process can take from several hours to several weeks. Observing your unit's LED test indicator labeled "Green OK Yellow Desulphate" is the easiest way to determine if desulphation is needed. Remember, to obtain an accurate condition,

you must test battery after it has "rested" = battery that is fully charged 8+ hours ago, without any load being applied to it.

**OPERATING INSTRUCTIONS:
DO NOT ATTEMPT TO OPERATE CHARGER BEFORE READING AND FULLY UNDERSTANDING ALL SAFETY INSTRUCTIONS AS OUTLINED PRIOR. CALL OUR TOLL FREE TELEPHONE NUMBER IF YOU HAVE ANY QUESTIONS WHATSOEVER.**

1. **BatteryMINDer** is designed to fully charge your battery(s), and should be left connected to the battery at all times the battery is not in use. Failure to maintain the battery in a full charge condition at all times will cause the battery to sulphate, seriously limiting it's life and performance. In addition, this ensures you will always have a fully charged battery. The amount of electricity it uses when the battery is fully charged is less than 10¢ month even when electricity costs as much as 18¢ /kWh. Compare this cost to needing to replace a battery after only one season of use due to sulphation caused by improper charging and/or storage.
2. After carefully reading and fully understanding the safety instructions, provided in these instructions, each time you wish to store your battery or whenever you will not be using it for a 4 days or more, simply attach **BatteryMINDer** as described in the safety instructions and let it do its job.

NOTE: It is normal for BatteryMINDer to feel warm to the touch during the charging cycle, especially with older and/or large batteries. Unit will begin to cool, when it nears the end of the charging mode and during the entire float maintenance + desulphation mode.

The Green LED desulphation and maintenance indicator will light when you have properly attached unit's clips to the battery posts ie: Red marked clip to (+) post and Black marked clip (-) post of battery. LED will begin to blink when battery has been fully charged and is now in the Auto-Float Maintenance and desulphation mode. The Red LED will come on when the unit is plugged into live 120 volt AC electrical outlet. It will remain on throughout the entire charging mode as well as during the float maintenance mode. **SHOULD THE Red indicator NOT REMAIN ON, CHECK TO BE SURE UNIT IS PLUGGED IN AND OUTLET IS STILL LIVE.** If outlet is live and Red LED does not light, unit is NOT PROPERLY CHARGING or MAINTAINING battery correctly. Disconnect unit and return immediately to VDC Electronics for inspection / repair or replacement.

NOTE: Certain of the Green LED indicators will light even when unit is not connected to a live outlet, as they are activated by the battery's own voltage. Do not leave BatteryMINDer connected to the battery without electrical power. The battery energy used to light these LEDs will cause battery to discharge over time.

IMPORTANT: It is recommended to charge large capacity deeply discharged batteries with your standard charger before attaching BatteryMINDer to minimize the time it takes for BatteryMINDer to enter the Desulphation Maintenance mode. If the Green LED does not start blinking within 72 hours after unit has been attached to a fully charged battery the BATTERY MAY HAVE A SHORTED CELL OR IS TOO HIGHLY SULPHATED TO ACCEPT A PROPER CHARGE. Do not continue. Disconnect the battery and have it load tested.

DE-SULPHATION BUTTON

If **BatteryMINDer** is unable to bring the battery up to a full charge voltage, it will not "blink" and will remain in the charge mode (solid Green), rather than going into the Maintenance Desulphator (blinking Green) mode. Your battery may not be able to be properly charged, or conditioned. However, by pressing the button the unit will go into the desulphation stage. You may then be able to save your battery. Leave your battery connected to **BatteryMINDer** for a minimum of 1 week before re-testing it.

Note: If your battery does not have a minimum "resting" voltage. It cannot be properly charged or de-sulphated. **Replace Battery. Minimum Resting Voltage: 12V = 10.5V, 24V = 21V, 36V = 31.5V** (*Resting Voltage = Voltage in a battery that has not been charged or discharged within 8 hours MINIMUM)

IMPORTANT: BatteryMINDer will have no electrical output unless it is connected to a "healthy" battery. Testing it with a Volt or Amp meter, without the unit being connected across a good battery, will result in a false reading. If you experience any problems or are not sure of how to properly use/connect your **BatteryMINDer**, please call our Toll-Free Technical Support line, 800-379-5579 number and leave us a detailed message explaining your problem.

Note: If your battery does not have a minimum "resting" voltage. it cannot be properly charged or de-sulphated. **Replace Battery** (*Resting voltage = Voltage in a battery that has not been charged or discharged within 8 hours MINIMUM)

Use your **BatteryMINDer** on your battery at ALL times (winter, summer, spring or fall) that your battery will not be used for 4 days or more. This will prevent new Sulphation from taking place and will lead to dramatically increased battery life and performance. **DO NOT REMOVE BatteryMINDer** from your battery unless you place the battery back in service.

FAILURE TO KEEP BatteryMINDer CONNECTED TO YOUR BATTERY AT ALL TIMES THE BATTERY IS NOT IN SERVICE WILL AFFECT PERFORMANCE CLAIMS.